

10.

To determine the wavelength of light from a Sodium Lamp by Newton's rings method.

10.1 THEORY

If we place a plano convex lens L on a flat glass plate G as shown in the figure, an air film of varying thickness is formed between the curved surface of the lens and the flat surface of the plate. Light from a Sodium lamp S falls on a flat glass plate P placed at 45° with respect to the incident beam. Some of this light is reflected at the plate and directed towards the lens and glass plate placed below. This light in turn is partially reflected upwards at all the four surfaces. Light reflected from the curved surface of the lens and light reflected from the adjacent surface of the glass plate then interferes to form a pattern of circular fringes.

Consider points lying close to the point of contact between the lens and the glass plate. We note that the path difference between the interfering beams is approximately $2t$, where t is

the thickness of the air gap. Since the light reflected from the glass plate G undergoes a further phase shift of π the condition for an interference maximum is,

$$2t = \left(n + \frac{1}{2}\right)\lambda, n = 0, 1, 2, 3, \dots \quad (10.1)$$

while the condition for a minimum is,

$$2t = n\lambda, n = 0, 1, 2, 3, \dots \quad (10.2)$$

As the system is axially symmetric the resulting fringes are concentric circles with the center at the point of contact. If R is the radius of curvature of the curved surface of the lens, it can be shown from geometry that the diameter of the n^{th} dark ring is given by,

$$D_n^2 = 4 \cdot t \cdot (2R) = 4n\lambda R \quad (10.3)$$

Similarly for the $(n + m)^{\text{th}}$ ring,

$$D_{n+m}^2 = 4(n + m)\lambda R \quad (10.4)$$

Subtracting equation 3 from equation 4 we get,

$$D_{n+m}^2 - D_n^2 = 4m\lambda R$$

i.e.

$$\lambda = \frac{D_{n+m}^2 - D_n^2}{4mR} \quad (10.5)$$

Thus measuring the diameter of the rings and the radius of curvature of the lens, we can find the wavelength of the light used.

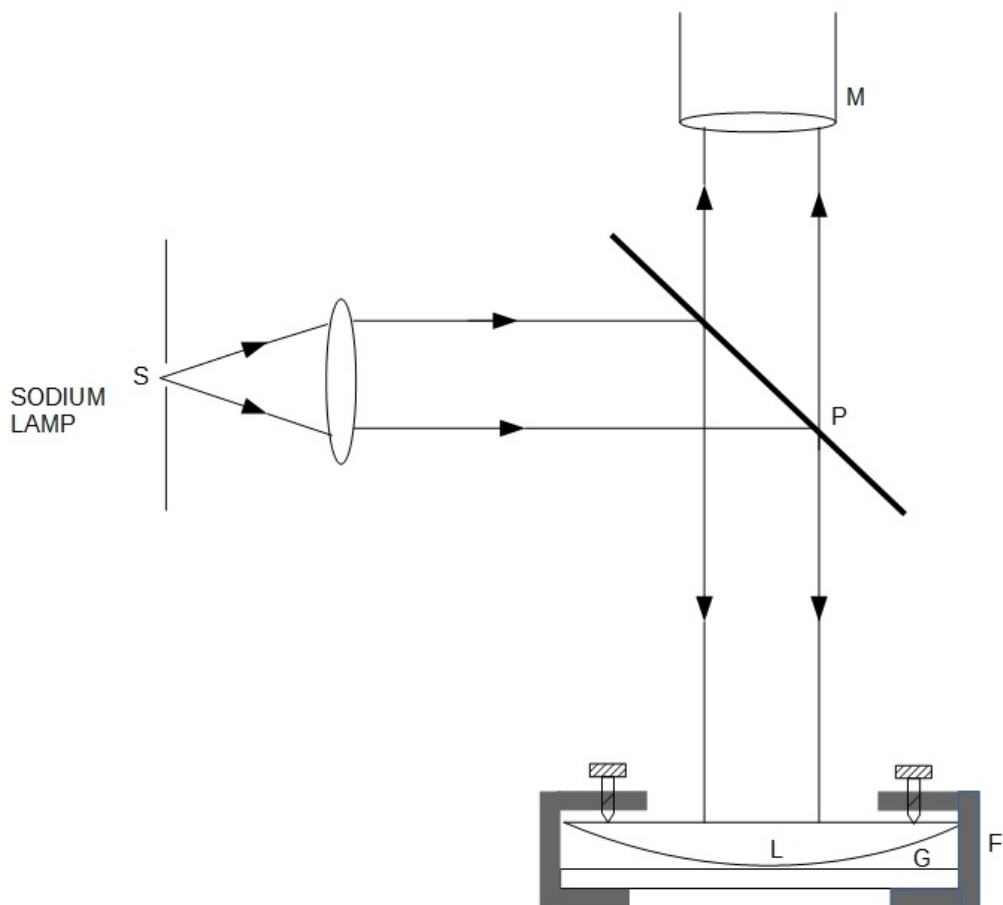
**PROCEDURE:**

1. Clean both surfaces of the lens and glass plate with a tissue paper and ensure that there is no fingerprint or grease on either. Place the curved surface of the lens on the glass plate. Check that this is correct by gently pressing on one edge of the lens, it should rock because of the curved surface being in contact. Place this assembly in the frame supplied and slightly tighten the screws to ensure that the lens will not fall but can move slightly if needed. Make sure that you do not over-tighten the

screws as this may break the lens or the glass plate.

2. Hold the lens-plate assembly horizontal while standing below any light on the ceiling of the laboratory. A circular pattern of interference fringes ($\sim 1\text{-}2$ mm dia.) should be visible in the light reflected from the assembly. If no fringes are visible then the glass surfaces have not been cleaned properly. If the fringes are very irregular in shape then the flat and not the convex surface of the lens is in contact with the plate.

3. The frame containing the lens and plate is then placed in the Newton's rings apparatus so that the fringes are directly below the microscope. The microscope is then moved vertically until the fringes can be seen. If necessary, one of the three screws on the frame can also be tightened slightly to tilt the lens and ensure that the fringes are centered.

4. At this stage, the central fringe should be dark if this is not so, then the plate and lens are not clean, take them out, clean them and perform the same procedure as above. To ensure maximum contrast, move the Newton's ring apparatus of the lens in front of the lamp till the other dark fringes are also as black as possible.

5. Find the vernier constant of the traveling microscope. Then using the micrometer, move the microscope in the horizontal direction and check that it can be moved to more than 25 dark and bright fringes on either side of the center for taking readings.

6. Counting carefully from the center move out till the cross wire is on the 21^{st} fringe or 22^{nd} bright fringe. Now rotate the

micrometer in the opposite direction till the 20th..fringe of the same type is tangential to the cross-wire. Note the position of the traveling microscope from the micrometer.

The 21st fringe must not be used as reversing the direction of the screw there gives a large backlash error.

7. Move the microscope using the micrometer to align the cross-wire tangential to the 18th fringe and note the micrometer reading. Repeat this on the 16th, 14th, 12th fringes, continue in the same fashion on the other side of the center till the 20th

8. Remove the plano convex lens and plate from the frame and lay the lens with the flat surface downwards. Raise the central screw of the spherometer and place the spherometer on the convex surface of the lens. Rotate the screw until the tip just touches the lens and note the reading on the spherometer. Now without disturbing the reading, lift the spherometer and place it on the flat glass plate. Again lower the screw till it touches the plate and note the new reading. Repeat this process two or three times and obtain the mean value of 'h': which is the difference of the two readings.

9. In order to measure l the distance between any two legs of the spherometer, press the spherometer down on your notebook so that the three legs make marks on it. Trace out the triangle thus made by the spherometer, measure all the three sides and take the mean. Use this h and l to find the radius of curvature R of the lens by the formula.

$$R = \frac{l^2}{6h} + \frac{h}{2} \quad (10.6)$$

Observations:

Least count of micrometer on microscope =

Pitch (least count of main scale) of spherometer =

Least count of vernier (circular) scale of spherometer =

Table 10.1: Measurement of the diameter of the fringes

Serial No.	No. of Ring n	Microscope Reading		Diameter = $D_n =$ left hand side – right hand side
		Left hand side	Right hand side	
1.	20	↓		
2.	18			
3.	16			
	:			
	:			↑

Calculations:

Serial No	Ring number n	D_{n+10}^2 ($m = 10$)	D_n^2	$\lambda = \frac{D_{n+m}^2 - D_n^2}{4mR}$
1	10			
2	8			
3	6			

Distance between two legs of the spherometer :

(1) (2) (3) Mean =

Serial No.	Spherometer Circular scale reading on lens	Spherometer Circular scale reading on plate	Difference of the two circular scale readings m	Number of complete rotations moved n	$h = n \times (\text{pitch}) + m \times (\text{least count of circular scale})$
1					
2					
3					

(Calculate the maximum possible error and report the result as below)

The wavelength of light from the Sodium lamp was found to be $= \lambda \pm d\lambda$ nm.

Points to think about:

1. What happens to the light reflected from the upper surface of lens and lower surface of glass plate?
2. Why is the center of the fringe pattern dark even though the path difference between interfering beams is zero?
3. What will you observe if white light is used in this experiment instead of sodium lamp?

