

Study of Electromagnetic Induction

7.1 Introduction

The basic principle of generation of alternating emf is electromagnetic induction* discovered by Michael Faraday. This phenomenon is the production of an induced emf in a circuit (conductor) caused by a change of the magnetic flux linking the circuit. Faraday's law of induction tells us that the induced emf E is given by

$$E = -\frac{d\phi}{dt} \quad (7.1)$$

where $d\phi/dt$ represents the rate of change of flux linking the circuit. If you use mks units, E will be in volts, \vec{B} in webers/meter², the flux ϕ in webers and t in sec. If, on the other hand you use Gaussian units, \vec{B} in gauss, ϕ in gauss cm^2 , then Eq.7.1 will

*It is said that when Faraday was asked about the use of his discovery he replied "what is the use of a new born baby?" Had faraday made the discovery in modern days, he would have been probably asked "What is the relevance of your discovery?" indicating the great progress we have made in the nuances of language; we are, however, not quite sure what Faraday would have replied.

read

$$E = -\frac{1}{c} \frac{d\phi}{dt} \quad (7.2)$$

where c is the speed of light in cm/sec and E will then be in ab volts.

For a discussion of the concept of flux and Faraday's law turn to Appendix I. The experiments described in this chapter will further help you to understand the phenomenon.

7.2 The Apparatus

It consists of a permanent magnet mounted on an arc of a circle of radius 50cm. The arc is part of a rigid frame of aluminium and is suspended at the centre of the arc so that the whole frame can oscillate freely in its plane[figure 7.1]. Weights have been provided, whose positions can be altered so that the time period of oscillation can be varied from about 1.5 to 3 sec. Two coils of about 10,000 turns of copper wire loop the arc so that the magnet can pass freely through the coil.

The two coils are independent and can be connected either in series or in parallel. The amplitude of the swing can be read from the graduations on the arc. When the magnet moves through and out of the coil, the flux of the magnetic field through the coil changes, inducing the emf.

In order to measure this emf, we resort to the now familiar trick of charging a capacitor through a diode and measuring the voltage developed across the capacitor, at leisure.[figure 7.2].

R represents the coil resistance(about 500ohms) plus the forward resistance of the diode. (If you introduce an additional resistance, that will also have to be included in R). The capacitors used are in range of $100\mu\text{f}$ and the charging time RC is of

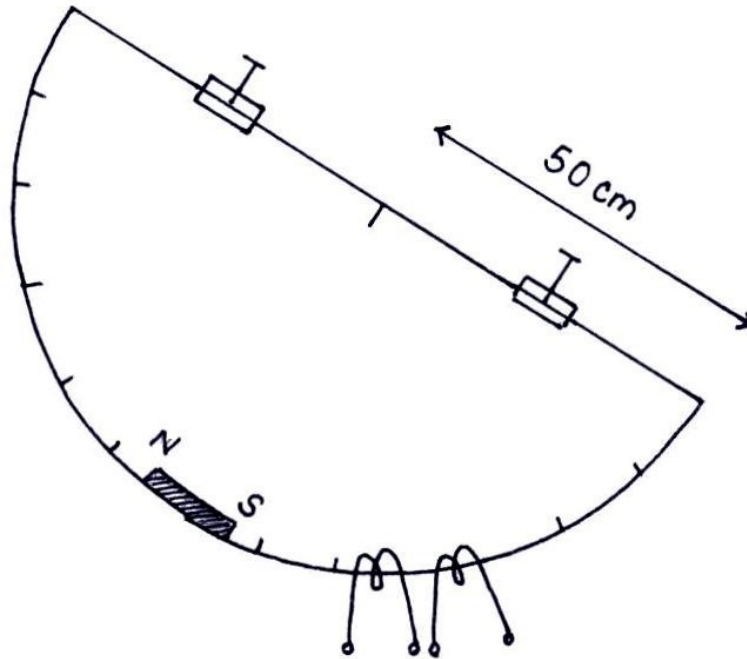

Figure 7.1:

the order of 40msec. It will turn out that this time is somewhat larger than the time during which the emf in the coil is generated so that the capacitor does not charge up to the peak value in a single swing and may take about 10oscillations to do so. This may be checked by the current meter in the circuit which will tell you when the charging current ceases to flow.

The peak value of the emf generated may also be measured by using null method in which one compares the varying emf with a d-c voltage. The arrangement is shown in figure 7.3. The voltmeter will record a 'kick' if the voltage across AB(potential divider) is smaller than the peak voltage developed across the coil so that all that is required is to increase the d-c voltage until the meter ceases to show any deflection. The part played by the capacitor is purely nominal. See if there is any difference in the

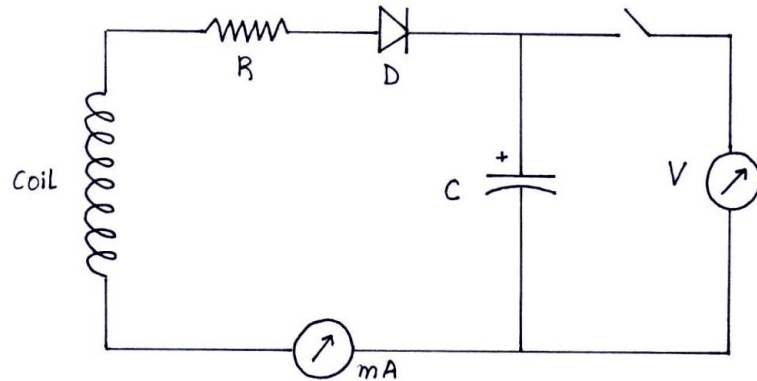

Figure 7.2:

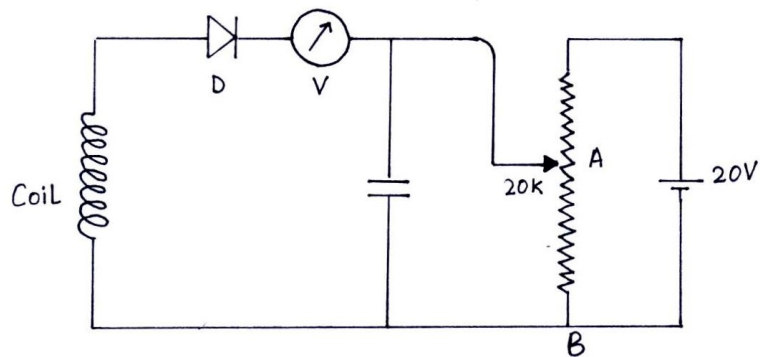

Figure 7.3:

performance without it. In the experiments, try to measure the induced emf by both the methods suggested above.

7.3 Experiment A

To study the emf induced as a function of the velocity of the magnet.

The magnet is placed at the centre of the arc. As the magnet

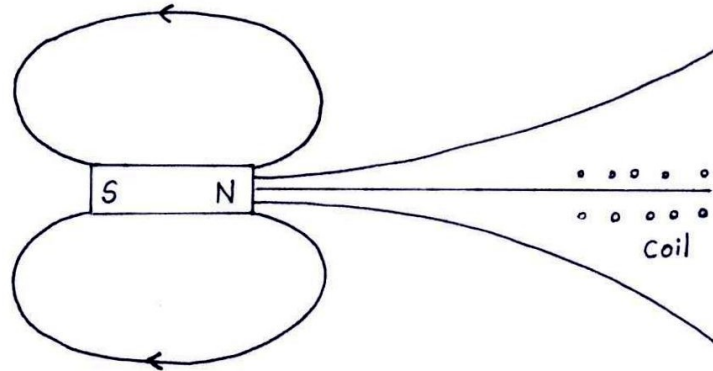

Figure 7.4: The magnetic field at the coil increases as the magnet approaches the coil

starts far away from the coil, moves through it and recedes, the magnetic field through the coil changes from a small value, increases to its maximum and becomes small again thus inducing an emf(Appendix I).

Actually, there is a substantial magnetic field at the coil only when it is very near the magnet; moreover, the speed of the magnet is largest when it approaches the coil since it is approximately in the mean position of the oscillation. Thus the magnetic field changes quite slowly when the magnet is far away and rapidly as it approaches the coil. Roughly, this is the way we expect \vec{B} (at the coil) to change with time.

The flat portion at the top, in figure 7.5 corresponds to the finite length of the magnet. Actually, the curve in figure 7.5 also tells us the way the flux ϕ changes with time since, with a stationary coil, it behaves the same way as \vec{B} . The induced emf will be negative time derivative of ϕ and will look like this:

The times t_1 and t_2 in figure 7.5 are the points of inflection of the curve and in figure 7.6 are obviously a minimum and

Figure 7.5: Variation of B at the coil with time

Figure 7.6: Variation of induced emf with time

maximum, respectively.

Remember, this sequence of two pulses, one negative and one positive, occurs during just half a cycle. On the return swing of the magnet, they will be repeated. (Which one will be repeated first, the negative or the positive pulse?)

Consider now the effect of these pulses on the charging circuit of figure 7.2. The diode will conduct only during the positive pulse; at the first half swing, the capacitor charges up to a potential, say about $0.5E_0$. During the next half swing, the diode will be cut off until the positive pulse reaches $0.5E_0$ and then the

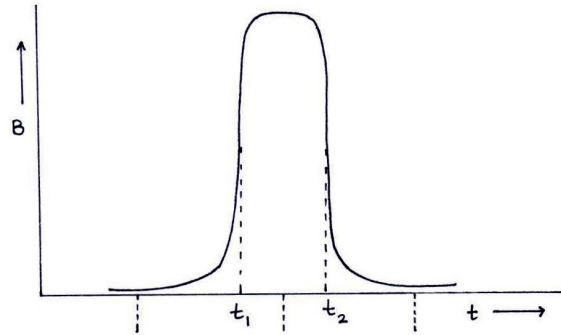
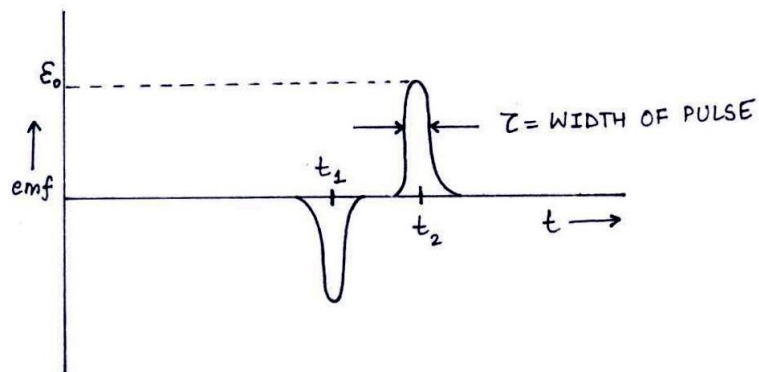
capacitor will be allowed to charge up to a slightly higher potential. Thus, in a few oscillations the capacitor will be charged up to the peak value E_o .

The rate of change of flux through the coil is, essentially, proportional to the velocity of the magnet as it passes through the coil. By choosing different amplitudes of oscillation of the magnet, we can alter this velocity. Suppose the angular velocity of the magnet at any point is ω and the moment of inertia of the system about the axis of rotation is K . The kinetic energy of the system is $\frac{1}{2}K\omega^2$ and the potential energy (referred to the lowest position of the magnet) is $Mgr(1 - \cos \theta)$ where M is mass of the system and r the distance of the centre of gravity from the point of suspension. The maximum value ω_{max} is given by

$$\frac{1}{2}K\omega_{max}^2 = Mgr(1 - \cos\theta_o) \quad (7.3)$$

or,

$$\omega_{max}^2 = \frac{2Mgr}{K}(1 - \cos\theta_o) \quad (7.4)$$

where θ_o is the angular amplitude. In order to eliminate the constants (Mgr/K) we note that the motion is approximately simple harmonic with a time period.

Conservation of energy gives

$$\frac{1}{2}K\dot{\theta}^2 + Mgr(1 - \cos\theta) = \text{constant}$$

where we have written ω for $\dot{\theta}$; for small θ this gives

$$\frac{1}{2}K\dot{\theta}^2 + \frac{1}{2}Mgr\theta^2 = \text{constant}$$

Differentiating this we obtain

$$\ddot{\theta} + \frac{Mgr}{K}\theta = 0$$

from which the time period given by eq 7.5 is readily written.

$$T = 2\pi\sqrt{\frac{K}{Mgr}} \quad (7.5)$$

From eqs.(7.4) and (7.5) we obtain

$$\omega_{max} = \frac{4\pi}{T} \sin \frac{\theta_o}{2} \quad (7.6)$$

The velocity of the magnet is given by

$$v_{max} = R\omega_{max} = R\frac{4\pi}{T} \sin \frac{\theta_o}{2} \quad (7.7)$$

where R is the distance of the magnet from the point of suspension.

The angular amplitude θ_o is determined by measuring the initial displacement S_o of the centre of the magnet from the mid-point of its oscillation since

$$\theta_o = \frac{S_o}{R} \quad (7.8)$$

Measure the length R directly. Fix the amplitude S_o at a certain value measured on a scale which is fixed on the arc housing the magnet and set the magnet in oscillation. The velocity of the magnet through the coil is readily commuted from Eqs.(7.7) and (7.8).

As the capacitor in figure 7.2 charges up, watch the ammeter and as soon as it shows that there is no more charge current, connect the voltmeter and measure the peak voltage V. (Alternatively, you may use the null method discussed).

Vary the velocity of the magnet v_{max} by choosing different values for S_o . For each velocity determine the peak voltage of the capacitor which is obviously a measure of the induced emf. A graph of the peak voltage vs v_{max} will yield a straight line in accordance with Faraday's law. Try with a number of values for S_o . You may also change the capacitor and observe the difference in the charging rate. In figure 7.7, we display the typical results of a measurement.

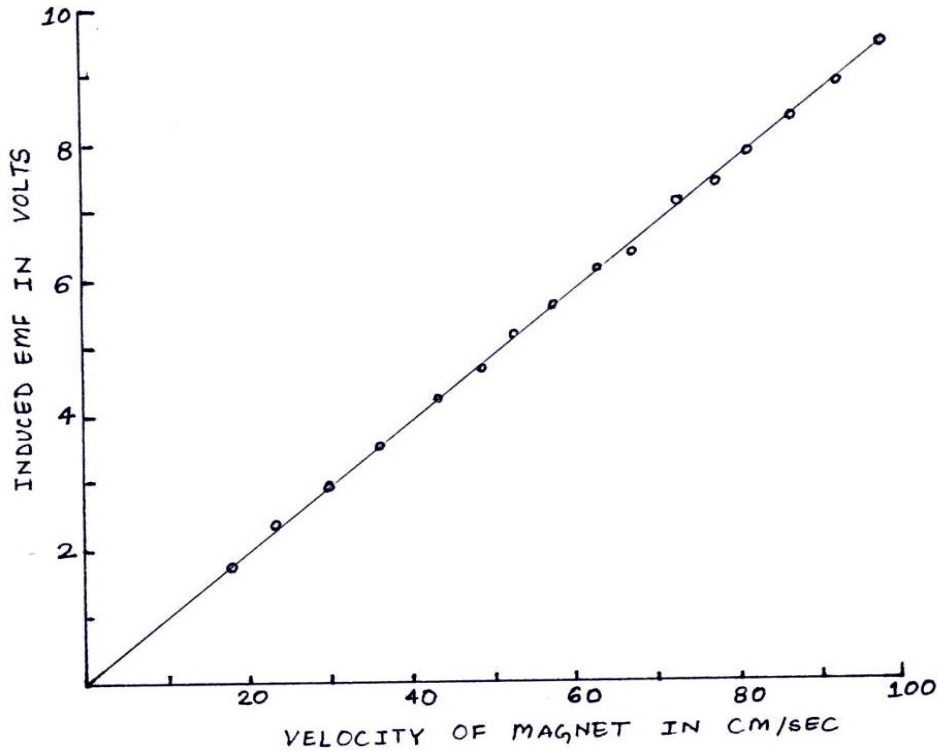

Figure 7.7:

7.4 Experiment B

To study the charge delivered due to induction

When the charging time (RC) of the capacitor is large, the charge collected over a small interval of time $t \ll RC$ is given by

$$Q(t) = \frac{1}{R} \int_0^t E(t) dt = -\frac{1}{R} \int_0^t \frac{d\phi}{dt} dt \quad (7.9)$$

$$Q(t) = \frac{1}{R} [\phi(0) - \phi(t)] \quad (7.10)$$

During each oscillation, the magnetic field at the coil changes from practically zero to its maximum value B_{max} when the mag-

net passes through the coil. The change in flux is approximately $B_{max} \vec{A} m$ where m is the number of turns and A the area of the coil, the charge Q is given by $Q = CV$ where V is the voltage acquired by the capacitor whose capacitance is C . Thus, Q can be readily measured. Eq(7.10) then will enable you to make a rough estimate of B_{max} .

Try using different resistors R in charging circuit and see how far Eq(7.10) is obeyed. The change in the flux ought to be the same so that the charge collected should be smaller the larger the value of R . If you find that the voltage of the capacitor is too small to be measured for a single swing, you may average over a small number of oscillations(why only a small number of oscillations?).

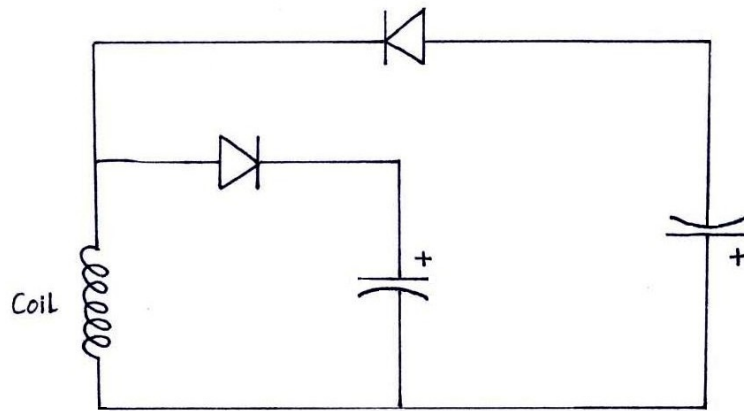

Figure 7.8:

As mentioned in Experiment A , the diode allows the capacitor to charge only for positive pulse [Figure 7.6]. You may arrange two sets of charging circuits as in [Figure 7.8] so that one capacitor charges up on the positive pulse and the other on the negative pulse. Verify that the charges on the capacitor are nearly the same. (What will the voltages on the capacitor

depend on?)

If you stop the oscillation (by hand) after a quarter oscillation (from the extreme position of the magnet to its mean position), only one capacitor will charge up. Try and find out if the sign of the emf induced is as should be according to Faraday's law.

7.5 Experiment C

To study electromagnetic damping

We have, so far, neglected damping of the oscillations of the magnet. Successive oscillation will not be of the same amplitude as you check from a rough measurement of the amplitude after, say 10 oscillations.

There are many reasons for this damping. There is always some air resistance; then again the system is not nearly free from friction at the point of suspension. But the most important (and interesting!) source is that the induced emf in the coil itself introduces a damping through a mechanism which goes by the name of Lenz's law. This law states that the direction of the induced emf is always such as to oppose the change that causes it. (See Appendix II for a discussion)

The energy dissipation will not be same after each oscillation; in fact as a rule in oscillatory systems, the fractional loss of energy turns out to be roughly constant. That is to say, suppose the energy of the system is E_n after n oscillations. Then

$$\frac{E_n}{E_{n-1}} = \alpha \quad (7.11)$$

where α is nearly independent of n . It is easy to see that this implies

$$\frac{E_n}{E_o} = \alpha^n \quad (7.12)$$

where E_o is the energy at the beginning.

Since the energy is proportional to the square of the amplitude, Eq.(7.12) gives

$$\frac{S_n}{S_o} = \sqrt{\frac{E_n}{E_o}} = \alpha^{n/2} \quad (7.13)$$

Thus if you plot a graph of $\log S_n$ as a function of n you ought to get a straight line. In practice, you will find that this is only approximately true.

First, keep the coil open circuited. Fix the amplitude of the magnet and measure the amplitude S after a number of oscillations. You will find that the amplitude is still considerable even after 200 oscillations, since in this case there is no electromagnetic damping at all. Plot $\log S$ as a function of n .

Next, try the same with a short circuited coil. This time the amplitude diminishes rapidly and about 20 oscillations or so are all that give measurable amplitudes. Again plot $\log S$ vs n . You may also connect a finite load such as a 500ohm resistor and make the same measurements. Finally, try also a big capacitor, say 2000 μ f, as a load. At each swing the capacitor keeps charging up and energy has to be supplied to build up this energy as well as the energy that will be lost through leakage. Try and interpret the graphs that you obtain in these cases; the case of a capacitive load is somewhat complicated. (Figure 7.9 shows these curves plotted from experimental data)

APPENDIX-I

Flux Of The Field And Faraday's Law

As pointed out at the beginning of this chapter, the concept of flux of the field is vital to the understanding of Faraday's Law.

Consider a small element of area $d\vec{\sigma}$. We assign a direction to this element taking it to be the normal to the plane of the area directed such that if it is bounded by a curve as shown in [Figure 7.10], then the normal comes out of the plane of the paper towards you, the reader. In other words, it is the same direction as the movement of the axis of a right handed screw rotated in the sense of the arrow on the curve.

Suppose, now this element of area is situated in a magnetic field \vec{B} . Then the scalar quantity

$$d\phi = \vec{B}d\vec{\sigma} = |B| |d\sigma| \cos(\theta) \quad (7.14)$$

is called the flux of \vec{B} through the area $d\vec{\sigma}$, where θ is the angle between the direction of the magnetic field and the direction assigned to the area $d\vec{\sigma}$.

We can generalize this to define the flux over a finite area \vec{S} . In doing this, we must remember that the magnetic field \vec{B} will not, in general, be the same at different points within the finite area. We therefore divide up the area into small pieces, calculate the flux over each piece and integrate. Thus, the flux is

$$\phi = \int_s \vec{B}d\vec{\sigma} \quad (7.15)$$

where the symbol s signifies that we are to integrate over the entire area \vec{S} . [Figure 7.11] Obviously, you cannot take \vec{B} out of the integral in Eq.(3.15) unless \vec{B} is same everywhere in \vec{S} .

If the magnetic field at every point changes with time as well, then the flux will also change with time.

$$\phi = \phi(t) = \int_s \vec{B}(t) \cdot d\vec{\sigma} \quad (7.16)$$

Faraday's discovery was that the rate of change of flux $d\phi/dt$ is related to the work done on taking a unit positive charge around the contour C[Figure 7.11] in reverse direction. This work done is just the emf. Accordingly, we can state Faraday's law in its usual form that the induced emf is given by

$$E = -\frac{d\phi}{dt} \quad (7.17)$$

If you look at Eq(3.16), you will see that even if \vec{B} does not change with time the flux may still vary if the surface S is somehow changing with time. Consider, for example, a frame of wires ABCD, as drawn in figure 7.12, situated in a constant magnetic field. If the side BC is moved out thus increasing the area of the loop ABCD, the flux of \vec{B} through the loop increase with time. Here also Faraday's law will apply as stated in Eq(3.17)***.

*** There are, however, a number of situations in which Faradays' law would not hold. For a beautiful discussion, read Feynman's Lectures in Physics, CH 17, Vol. II

APPENDIX-II

Lenz's Law

This law is just the statement of the tendency of a system to resist change as applied to the phenomenon of electromagnetic induction. Let us understand the origin of the law.

Suppose we have a steady current I in a circular loop as in figure 7.13. Then there is a magnetic field \vec{B} associated with this current, the lines of force going through the face of the coil and out is shown in the figure. The lines of force close upon themselves outside the coil. (The lines of force representing \vec{B} always close upon themselves). Note particularly the direction of these lines. The way to remember this is to ask yourself how the axis of a right handed screw, rotated in the direction of the arrow on the coil, will move. This is the direction of the magnetic field.

Suppose you increase the current. This will increase the magnetic field in the direction drawn and the flux will increase. But according to Faraday's law this increase in flux will set up an induced emf given by the rate of change of this flux, i.e.

$$E = -\frac{d\phi}{dt} \quad (7.18)$$

Note the negative sign. This means that the direction of the emf in the coil will be opposite the sense of rotation of a right handed screw. Thus the induced emf will try to restore the original current. This is why we have, on occasion, called it the back emf. If, therefore, the current in the coil has to be increased, one has to supply energy to overcome this opposing emf.

It is quite easy to see how much energy is required without going into details of this opposing field. Recall that a coil of self inductance L carrying a current I has an energy $\frac{1}{2}LI^2$. If, therefore, the increased current is I_o , the extra energy to be supplied is $\frac{1}{2}LI_o^2 - \frac{1}{2}LI^2$. You must now be able to argue why the open circuited coil in Experiment C is damped much less than a short circuited one.

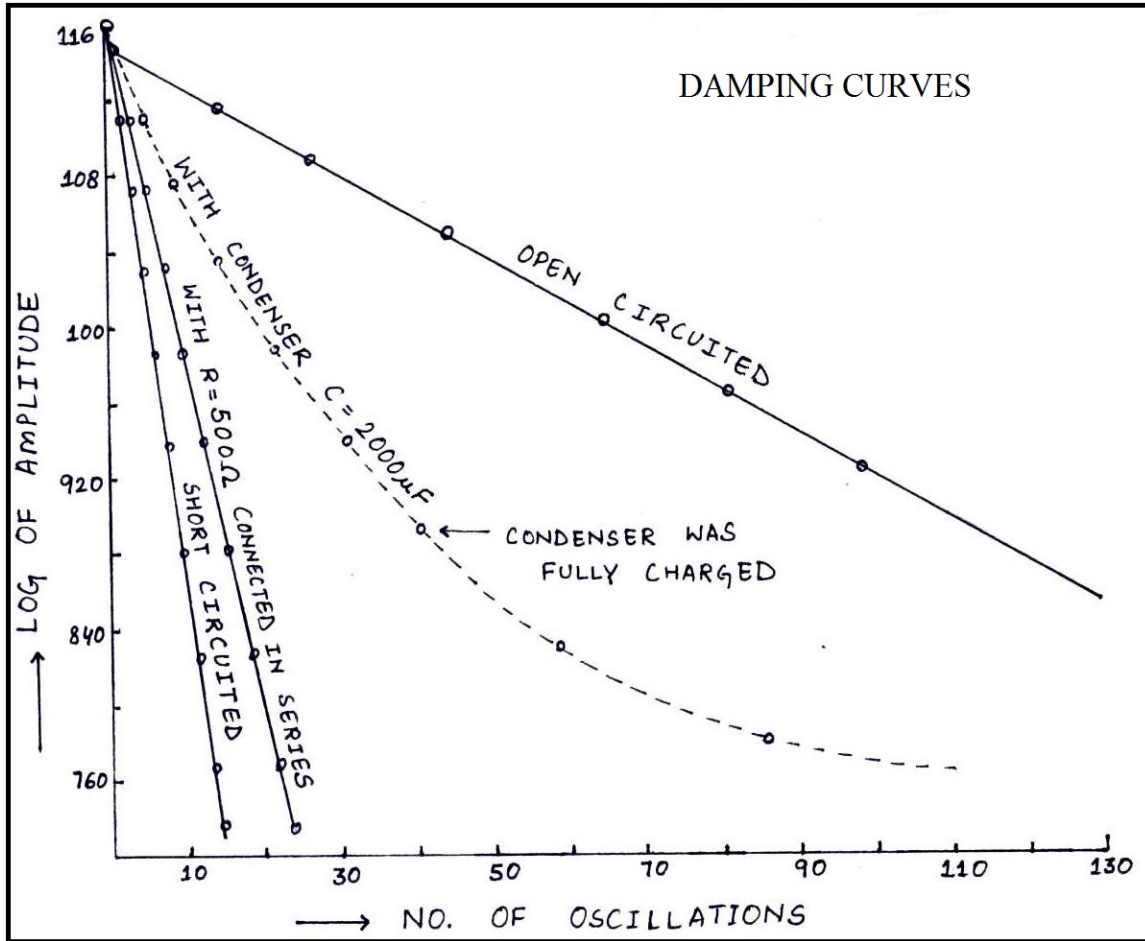

Figure 7.9:

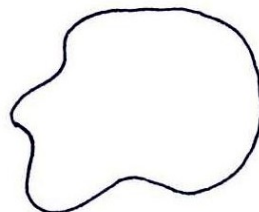

Figure 7.10:

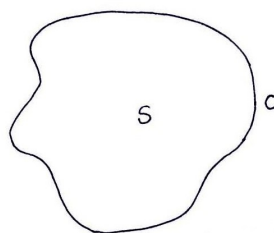

Figure 7.11:

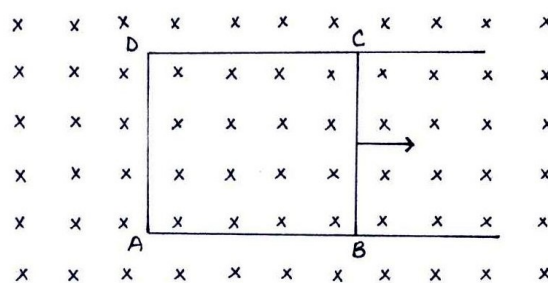

Figure 7.12:

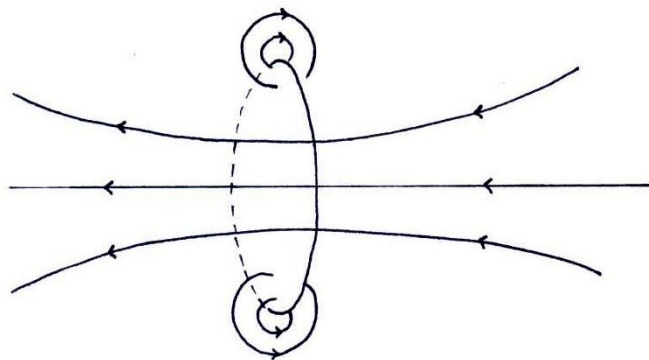

Figure 7.13: Field due to a circular coil carrying current